

# WWG3



**HIGH PRESSURE PACKAGED SUPERHEATED BOILER, GENUINE THREE PASS FIRE TUBE, HIGH PERFORMANCES, 95% EFFICIENCY**

OUTPUT RANGE	from 1200 to 18000 kW							
TYPE	STD				HP			
	smooth pipe				BIMETALLIC pipe			
FUEL	gas / LPG / light & heavy oil				gas / LPG			
WORKING PRESSURE	6 bar (WWG3 6) / 10 bar (WWG3 10) or higher pressure on request							
WORKING TEMPERATURE	164.3°C (WWG3 6) / 183.2°C (WWG3 10)							
MODELS	1200	1400	1800	2300	2900	3500	4000	4650
	5800	7000	8300	10000	12000	15000	18000	-

## DESCRIPTION

**Superheated water boiler, genuine three pass fire tube type, with 3 effective smoke passes, 91% efficiency<sup>(1)</sup>.**

The WWG3 series is a family of superheated water boilers, monobloc, designed for a maximum safety pressure of up to 10 bar, or higher on request, and an output from 1200 to 18,000 kW. It can work with liquid or gaseous fuels.

Each model is complete with adjustments and safety accessories for automatic operation and easy commissioning.

According to current legislation, the WWG3 family of superheated water boilers has been subjected to a conformity assessment by a Notified Body. Compliance with the Essential Safety Requirements of the European Directive PED 2014/68 / EU is guaranteed by the CE marking.

### General characteristics:

In the boiler with 3 effective smoke passes, the gases from the combustion chamber (1st pass) enter the inversion chamber from where they are pushed, along the first series of smoke pipes (2nd pass), towards the front smoke chamber; from here, along the second series of smoke pipes (3rd pass) they reach the rear smoke chamber and are conveyed to the chimney. The boiler has been sized to ensure a low thermal load in the combustion chamber, low surface load and low polluting emissions (values  $\leq 100$  mg/kWh) with Low NOx burner).

- **Boiler body:** designed in compliance with the standard EN 12953-3: it consists of a cylindrical outer shell with a wet bottom furnace and set-in tube plates, in high quality steel. All the materials used are accompanied by manufacturing certificates certifying their chemical and mechanical characteristics and controls during the production cycle and therefore their suitability for use. Weldings is carried out by suitably qualified personnel, according to approved procedures, and subjected to Non-Destructive Testing according to an internal "Manufacturing and Control" plan. When manufacturing is complete, the boilers are subjected to hydraulic testing in compliance with the requirement 7.4 - Annex 7 of the PED Directive 2014/68 / EU.
- **The smoke pipes:** in high quality steel, without helical turbulators, they are welded to the tube plates using qualified automatic procedures.
- **Reversing chamber:** completely water-cooled, it is made of welded steel sheet, connected to the furnace with a re-edged plate and to the rear smoke chamber with supports. For models from 4650 included it is equipped with a manhole (for smaller models the manhole is available on request).

■ **Front smoke chamber:** In the models from 1200 to 4000 kW the front chamber is made of welded steel sheet, internally lined with a layer of insulating material and a layer of high thickness refractory material. It is mounted on hinges that allow for quick opening and adjustment. If necessary, it is possible to reverse the opening direction. The door is also equipped with a self-cleaning flame sight glass for controlling combustion during burner operation.

In the models from 4650 kW and up, it consists of two doors in welded steel sheet, internally lined with a layer of insulating material and a layer of high thickness refractory material., which are used for cleaning and inspection. These are mounted on hinges for easy opening. Above the hole for the burner blast tube there is a self-cleaning flame sight glass for checking combustion during burner operation. In this range the burner doesn't need to be removed for tube bundles cleaning.

- **Rear smoke chamber:** it is made of welded steel sheet and externally coated with a layer of insulating material. Equipped with two doors for cleaning and inspection Complete with horizontal flue gas connection to the chimney, with a diameter sized for the power of the boiler and, for models from 4650 included, with a self-cleaning flame sight glass for combustion control. The rear smoke chamber can be equipped with an external economizer.
- **Base:** consists of a frame in electro-welded boxed steel sections, equipped with support saddles for the outer shell of the body under pressure, and equipped with a system that allows to compensate for thermal expansion.
- **Walkway:** positioned in the upper part of the boiler, it is built in steel and covered with checkered plate and completed, on request, with parapet and access ladder, compliant with the EN ISO 14122 Standard.
- **Outer shell insulation:** thermal insulation is ensured by a 100 mm thick mineral wool mattress, bonded with heat-resistant resins, suitably supported and protected externally by a 10/10 mm painted aluminum casing.

### Composition of the standard supply: <sup>(2)</sup>

- n. 2 spring-loaded safety valves
- Counter-flanges for connecting the flow & return pipes
- n. 1 manual boiler drain valve
- n. 1 large dial thermometer
- n. 1 large dial pressure gauge with 3-way tap for calibration
- n. 2 thermostats for burner adjustment (on control panel)
- n. 1 safety pressure switch with manual reset (from panel board), CE certified
- n. 1 safety thermostat with manual reset (from panel board), CE certified
- Burner plate for burner mounting, (with specific drilling for the burner type, on request)
- Lifting eyes
- Electric control panel, IP 55 - 400 V - 3 Ph + N - 50 Hz
- Documents envelope containing:
  - Manufacturer's Declaration of Conformity according to Annex VII of the PED Directive 2014/68 / EU
  - Installation, Use and Maintenance Manual.
  - Certifications relating to the installed safety components
  - Electrical diagram of the panel board and relative Declaration of Conformity.
  - Characteristics of the water: requirements of the feed water, boiler water: frequency and types of tests to be done on the samples.

(1) This value is intended without economizer and may vary according to the pressure, the operating load and other conditions such as CO<sub>2</sub> value, ambient temperature, water return temperature.

(2) Quantities, types or models may vary according to the configuration offered.

## TECHNICAL DATA

Model	Nominal output	Nominal input mod. STD	Nominal input mod. HP	$\Delta P$ smoke side STD	$\Delta P$ smoke side HP	Water content	Empty weight WWG3 6	Empty weight WWG3 10
	kW	kW	kW	mbar	mbar	lt	kg	kg
1200	1200	1318.7	1263.2	4.0	7.5	2830	5280	6200
1400	1395	1533	1468.4	6.0	10.0	3600	5985	6800
1800	1750	1923.1	1842.2	5.0	10.0	4950	6510	7400
2300	2300	2527.5	2421.3	4.5	8.5	5850	8100	9200
2900	2900	3186.8	3052.6	5.0	10.5	6545	9680	11000
3500	3500	3846.2	3684.2	5.0	10.5	8200	10825	12300
4000	4000	4395.6	4210.5	6.0	11.0	9175	11440	13000
4650	4650	5109.9	4894.7	7.5	12.0	11000	13200	15000
5800	5800	6373.6	6105.3	5.8	11.0	12520	15490	17600
7000	7000	7692.3	7368.4	7.0	14.0	14700	16900	19200
8300	8300	9120.9	8736.8	7.0	14.0	16800	19360	22000
10000	10000	10989	10526.3	10.0	15.4	20350	22880	26000
12000	12000	13186	12631.5					
15000	15000	16483	15789.5					
18000	18000	19780	18947.3					

data available on request

## DIMENSIONS

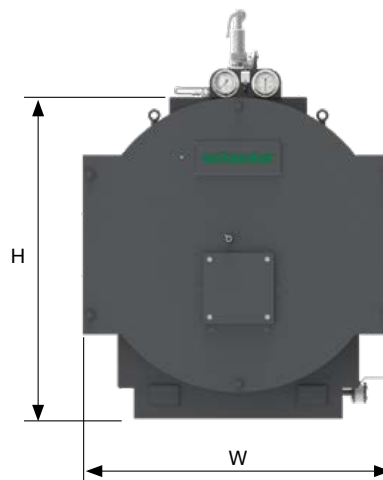
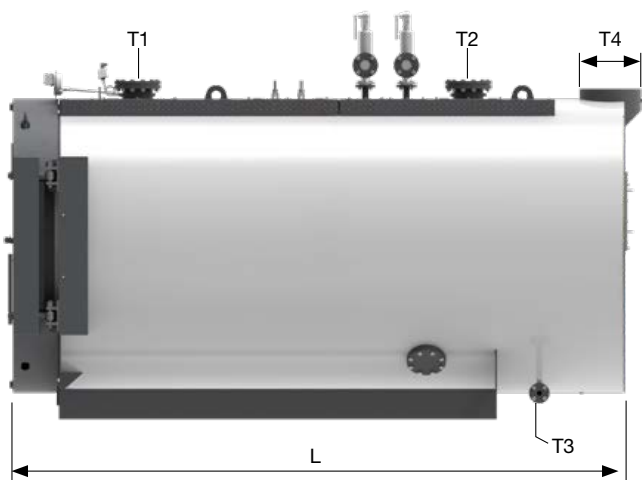

Model	W	L	H	T1/T2	T3	T4
	mm	mm	mm	DN	DN	Øi mm
1200	1840	3400	2150	150	40	354
1400	1840	3700	2150	150	40	354
1800	2130	3885	2400	150	40	404
2300	2255	4270	2450	150	40	454
2900	2255	4520	2535	200	40	454
3500	2425	5080	2795	200	40	554
4000	2425	5320	2795	200	40	604
4650	2520	5770	2890	200	40	604
5800	2670	6370	3000	250	40	704
7000	2670	6870	3000	250	40	704
8300	2830	7320	3210	250	40	804
10000	3030	7590	3345	300	40	904
12000/15000/18000						

data available on request

The company reserves the right to modify / adapt the technical and dimensional information of the products included in this catalog, even without notice, in order to improve the quality of the products themselves.

## PRODUCT PLUS VALUES

### ■ FRONT AND REAR DOOR

placed on both sides to get access to the tube bundles. They can be opened without the removal of the burner and the chimney for an easy service

### ■ LOW EMISSIONS $NO_x < 80 \text{ mg/kWh}$

thanks to the reduction of the specific thermal load (according to the versions)

### ■ WET BACK FURNACE

### ■ POSSIBLE COMBINATION

with one /two/three stage or modulating burners, operated with natural gas, LPG, light oil or heavy oil

### ■ EASY TRANSPORTATION

thanks to the upper hooks and the strong frame side members

### ■ DELIVERY

Is complete with board panel, safety and control devices

## TYPE OF PIPES

### TUBO LISCIO (STD)

suitable for gas, light and heavy oil operation, they increase the thermal exchange and allow the removal of the residual combustion products.

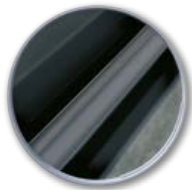

### BIMETALLIC PIPE (HP)

an aluminium multiradial profile, bound by rolling, is inserted within the steel pipes in order to increase the exchange surface and efficiency.



## OPTIONAL EQUIPMENT

### ELECTRICAL CABINET IML\_SH

- Control PLC
- 7" touch screen display (or superior) with graphic interface
- Single and two-stage, three-stage, modulating burner control
- Possible 24/72 h exemption
- No. 1 low level safety PED level switch (optional)
- Terminal board on quick coupling connectors
- Expansion with optional kits
- IP55 Protection rating



### ECONOMIZER

Heat exchanger smoke / water with exchange battery with finned pipes suitable for operation with natural gas / LPG or light oil.

**Average efficiency recovery: 5%**

- Flanged connections for water inlet and outlet
- Box for connection boiler /chimney

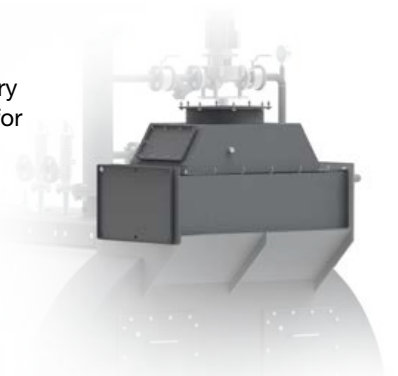

### 24 h EXEMPTION KIT

Set of accessories to obtain the partial exemption of the burner (24 h) according to European dir. n. 2014/68/EU transposed by DLgs. n. 26 of 15/02/2016, D.M. n. 94 of 07/08/2020 All. 3 - P.to 1.1 letter c, D.M. 1 December 2004 n°329, UNI/T S 11325-3:2018 and guidelines H/15 e I/20.

Consisting of:

- 24h exemption control panel including a timer and preset for a 24h exemption reset procedure
- Instrument/safety device wood log to be mounted on the boiler flow, with all equipment required and namely:
  - 1 pressure gauge with a pressure gauge valve
  - 1 large dial thermometer with a limit indication
  - 1 maximum and minimum safety pressure switch
  - 1 reflection level indicator with shut-off valves
  - 1 fail-safe minimum level safety probe
  - 2 fail-safe self-controlled temperature switch units (PT100), TRD604 CAT. IV.

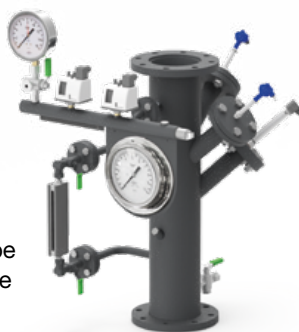

### 72 h EXEMPTION KIT

Set of accessories to obtain the partial exemption of the burner (72 h) according to European dir. n. 2014/68/EU transposed by DLgs. n. 26 of 15/02/2016, D.M. n. 94 of 07/08/2020

All. 3 - P.to 1.1 letter c, D.M. 1 December 2004 n°329, UNI/T S 11325-3:2018 and guidelines H/15 e I/20.

Consisting of:

- Control panel for up to a 72h exemption, including a timer and preset for a 72h exemption reset procedure
- Instrument/safety device wood log to be mounted on the boiler flow, with all equipment required and namely:
  - 1 pressure gauge with a pressure gauge valve
  - 1 large dial thermometer with a limit indication
  - 1 maximum and minimum safety pressure switch
  - 1 reflection level indicator with shut-off valves
  - 1 fail-safe minimum level safety probe
  - 2 fail-safe self-controlled temperature switch units (PT100), TRD604 CAT. IV.