



ILDE		8	10
CLASSE ENERGETICA		A+	A+
DIMENSIONI (LxPxH)	cm	49x56x110	49x56x110
PESO STUFA	kg	100	100
POTENZA TERMICA INTRODotta (min.-max)	kW	3,2 - 9,0	3,2 - 11,1
POTENZA TERMICA RESA (min.-max)	kW	3,1 - 8,1	3,1 - 9,8
RENDIMENTO POTENZA % (min.-max.)	%	94,5 - 90,7	94,5 - 88,9
TIRAGGIO MINIMO CAMINO	Pa	12	12
DIAMETRO SCARICO FUMI	mm Ø	80	80
DIAMETRO CONDOTTO ASPIRAZIONE	mm Ø	50	50
CAPACITÀ SERBATOIO	kg	22	22
CONSUMO PELLETT min.-max	kg/h	0,67 - 1,85	0,67 - 2,30
ASSORBIMENTO ELETTRICO nominale	W	40	41,6
ASSORBIMENTO ELETTRICO accensione	W	281	281
VOLUME RISCALDABILE	m ²	210	260

INCENTIVO CONTO TERMICO 2.0

Fascia climatica	A	B	C	D	E	F
ILDE 8	€ 504	€ 714	€ 925	€ 1.177	€ 1.429	€ 1.513
ILDE 10	€ 552	€ 783	€ 1.013	€ 1.290	€ 1.566	€ 1.658

PLUS PRODOTTO



STUFA VENTILATA



VETRO CERAMICO



BRACIERE IN ACCIAIO



MODULAZIONE DI POTENZA



USCITA FUMI POSTERIORE



DISPLAY TOUCH



MANIGLIA "MANO FREDDA"



PROGRAMMAZIONE GIORNALIERA / SETTIMANALE



FUNZIONE "SILENT"



ACCENDITORE AL QUARZO



WI-FI U-in

OPTIONAL



IONIZZATORE ARIA



TELECOMANDO



Nero



Bianco



Bordeaux





Vista frontale

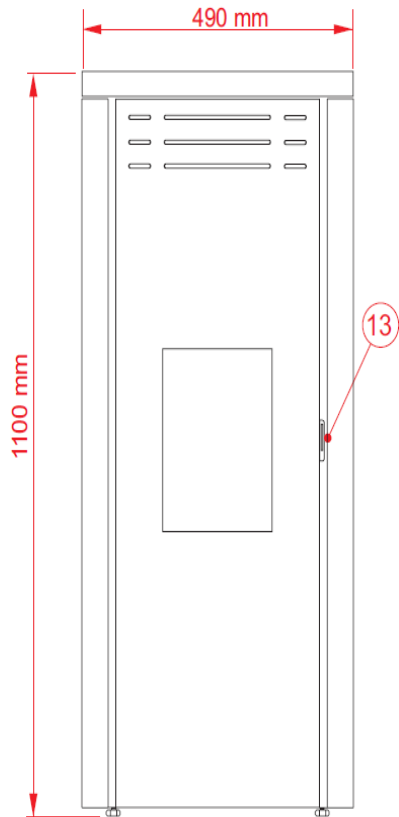

Vista Laterale Sx

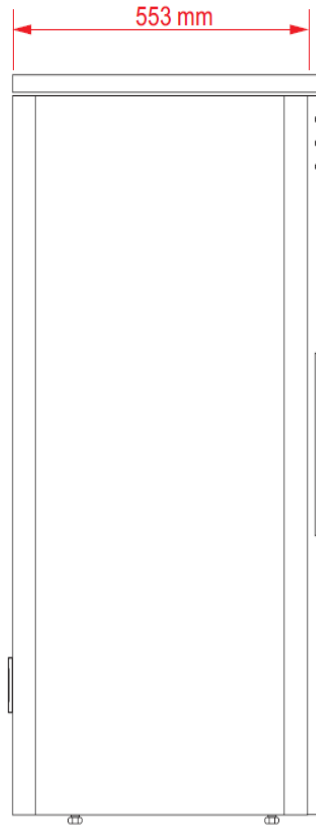

Vista posteriore

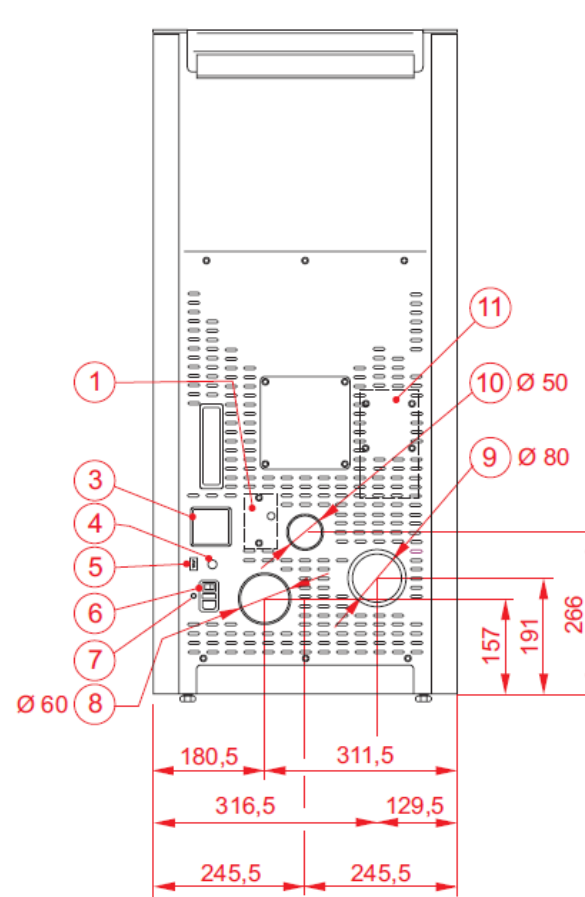

Vista superiore

